

Model of Interactions that Lead to Spine Formation

The EphB2 receptor tyrosine residues phosphorylate syndecan-2, which is required for spine formation.

complex has been formed. EphB2 phosphorylates syndecan-2 on two cytoplasmic tyrosines, and this phosphorylation is necessary for the association of EphB2 and syndecan-2. Thus, these molecules fail to come together if the kinase domain of EphB2 is inactivated or if the two critical tyrosines in the cytoplasmic tail of syndecan-2 are mutated to phenylalanine. EphA3 and EphA4 receptors do not phosphorylate or bind to syndecan-2, indicating that this interaction is specific for the B subclass Eph receptors.

Ethell et al. (2001) went on to study whether EphB2 tyrosine phosphorylation of syndecan-2 is required for formation of dendritic spines. Strikingly, they found that expression of a kinase-inactive EphB2 receptor blocked spine formation in a dominant-negative fashion. Likewise, expression of the double tyrosine mutant version of syndecan-2 also failed to induce spine formation in hippocampal cultures. These results indicate EphB receptor phosphorylation of syndecan-2 is required for the localization of these two proteins to developing spines and that this activity is necessary for the maturation of the spines. When combined with the work of others, the present study argues that EphB2 has important roles in the recruitment of many synaptic players, including the GRIP, PICK1, and AF6 PDZ-domain proteins, NMDA receptors, as well as syndecans. Thus, Eph-ephrin signaling may play a central role in synapse development and function.

The discovery that EphB2 kinase activity mediates syndecan-2 clustering and spine morphology suggests that these postsynaptic functions may be regulated by ephrin activation of the receptor. The fact that B-type ephrins can also signal into their own cell raises the question of whether this reverse signaling may play similar roles in the clustering of proteins and maturation of the presynaptic membrane. Analysis of mice carrying mutations in the genes encoding EphB receptors and their corresponding ephrins, although potentially complicated due to the notorious redundancy between fam-

ily members, may help to unveil the role of these molecules in the development and plasticity of synapses.

Mark Henkemeyer¹ and Jonas Frisé²

¹Center for Developmental Biology
University of Texas Southwestern Medical Center
Dallas, Texas 75390

²Department of Cell and Molecular Biology
Medical Nobel Institute
Karolinska Institute
SE-171 77 Stockholm
Sweden

Selected Reading

- Bernfield, M., Gotte, M., Park, P.W., Reizes, O., Fitzgerald, M.L., Lincecum, J., and Zako, M. (1999). *Annu. Rev. Biochem.* 68, 729–777.
- Buchert, M., Schneider, S., Meskenaite, V., Adams, M.T., Canaani, E., Baechi, T., Moelling, K., and Hovens, C.M. (1999). *J. Cell Biol.* 144, 361–371.
- Cowan, C.A., and Henkemeyer, M. (2001). *Nature* 413, 174–179.
- Dalva, M.B., Takasu, M.A., Lin, M.Z., Shamah, S.M., Hu, L., Gale, N.W., and Greenberg, M.E. (2000). *Cell* 103, 945–956.
- Ethell, I.M., and Yamaguchi, Y. (1999). *J. Cell Biol.* 144, 575–586.
- Ethell, I.M., Irie, F., Kalo, M.S., Couchman, J.R., Pasquale, E.B., and Yamaguchi, Y. (2001). *Neuron* 31, this issue, 1001–1013.
- Frisé, J., Holmberg, J., and Barbacid, M. (1999). *EMBO J.* 18, 5159–5165.
- Hock, B., Bohme, B., Karn, T., Yamamoto, T., Kaibuchi, K., Holtrich, U., Holland, S., Pawson, T., Rubsamén-Waigmann, H., and Strebhardt, K. (1998). *Proc. Natl. Acad. Sci. USA* 95, 9779–9784.
- Rapraeger, A.C. (2001). *Semin. Cell. Dev. Biol.* 12, 107–116.
- Sanes, J.R., and Lichtman, J.W. (1999). *Annu. Rev. Neurosci.* 22, 389–442.
- Torres, R., Firestein, B.L., Dong, H., Staudinger, J., Olson, E.N., Huganir, R.L., Bredt, D.S., Gale, N.W., and Yancopoulos, G.D. (1998). *Neuron* 21, 1453–1463.
- Yuste, R., and Bonhoeffer, T. (2001). *Annu. Rev. Neurosci.* 24, 1071–1089.

NMDA Receptors Turn to Another Channel for Inhibition

Activation of glutamate receptors generally increases neuronal excitability. However, Isaacson and Murphy show in olfactory bulb granule cells that NMDA receptor-mediated calcium influx couples to large conductance (BK) calcium-activated potassium channels. The resulting inhibition is long lasting, which may be critical to the operation of the dynamic circuitry of the bulb.

NMDA receptors are widely known for their ability to mediate changes in synaptic plasticity, due to calcium flux through the receptor. However, increasing evidence indicates that they can also mediate more direct, short-term effects on neuronal excitation. One of the more striking examples of this phenomenon was shown recently in the olfactory bulb, at dendrodendritic synapses between excitatory mitral cells and inhibitory granule

cells. NMDA receptors on granule cell dendritic spines can mediate not only a direct depolarization of granule cells, due to the influx of cations, but calcium influx through the receptor also can trigger dendritic release of GABA (Chen et al., 2000; Halabisky et al., 2000). Within the hippocampus, NMDA receptors can mediate short-term inhibitory effects (Nicoll and Alger, 1981; Zorumski et al., 1989). The mechanism underlying this inhibition, as well as whether such responses can be driven by synaptically released glutamate, however, has remained unclear.

Isaacson and Murphy report in this issue of *Neuron* (Isaacson and Murphy, 2001) perhaps the best example to date of a short-term inhibitory effect due to NMDA receptor activation, again employing the olfactory bulb system. While recording from the inhibitory granule cells in bulb slices, they found that application of glutamate elicited an outward current that was sensitive to blockers of both NMDA receptors and large conductance (BK) calcium-activated potassium channels. The glutamate-evoked BK current was due to a direct action of NMDA receptor-mediated calcium influx, rather than activation of voltage-gated calcium channels or intracellular calcium stores. The BK current could also be evoked by synaptic activation following electrical stimulation in the granule cell layer. Because the current required repetitive stimulation and was augmented by blockade of glutamate uptake, they suggest that the NMDA-evoked IPSP is mediated by extrasynaptic NMDA receptors.

These data clearly indicate that NMDA receptors can inhibit neurons due to their functional coupling to potassium channels and, moreover, that such coupling could have physiological consequences. However, a number of questions remain. One is the location of the NMDA receptor/BK channel coupling with respect to the site of synaptic glutamate release. The activation of synaptic NMDA receptors, as well as extrasynaptic receptors, would be expected to be augmented by repetitive stimulation or blockade of glutamate uptake. Additionally, the authors propose in their model that BK channels are activated by glutamate released from mitral cell axon collaterals terminating at or near the granule cell soma, based on immunocytochemical evidence that BK channels are localized in the granule cell layer (Knaus et al., 1996). However, it is likely that dendrodendritic synapses were also activated by their stimulation; thus, it remains possible that BK channels on granule cell dendrites contribute to the IPSP.

A second issue is the nature of interaction between NMDA receptors and BK channels. While studying the more "classical" coupling between voltage-gated calcium channels and calcium-activated potassium channels, Marrion and Tavalin (1998) found in hippocampal neurons that there was a selective, tight association between N-type calcium channels and BK channels. Based on the insensitivity of the current to the "slow" and "fast" calcium buffers EGTA and BAPTA, they estimated that the two proteins were separated by less than 30 nm. In the bulb, Isaacson and Murphy found that the glutamate-evoked current was insensitive to EGTA, but blocked by BAPTA. These results suggest that NMDA receptor coupling to BK channels is not as tight as that

N channel/BK channel: rapid inhibition

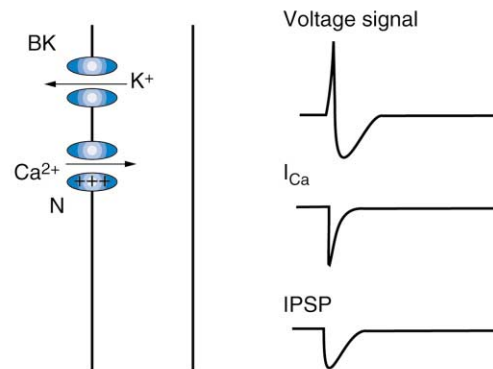

NMDA receptor/BK channel: slow inhibition

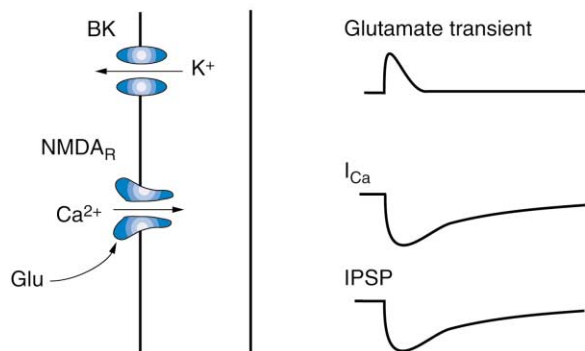

Kinetics of Inhibition Depend on the BK Channel Coupling Mechanism

seen between N-type calcium channels and BK channels. Moreover, a very tight association between NMDA receptors and BK channels may not be necessary. Within the hippocampus, the association between N-type calcium channels and BK channels produces extremely rapid temporal coupling between an action potential and the fast afterhyperpolarization. Such tight temporal coupling may offer little advantage to the granule cell, where the onset of potassium current activation would be limited by the relatively slow diffusion of glutamate to extrasynaptic NMDA receptors.

It will be interesting to determine the contribution of the NMDA receptor-mediated calcium transient to BK channel activation following natural stimulation. Because granule cells do spike in response to odor (Wellis and Scott, 1990), they could display large BK currents due to calcium ions entering through voltage-gated calcium channels. The source of calcium has important functional consequences for the kinetics of inhibition (see Figure). Because the duration of both the action potential and the calcium tail current is on the order of a millisecond, the tight coupling between calcium channels and BK channels produces rapidly developing yet short-lived inhibition. In contrast, the slow deactivation kinetics of NMDA receptors produces a longer-lasting calcium signal that drives inhibition. The source of calcium also affects the ability of inhibitory granule cells to suppress the activity of mitral cells. A calcium chan-

nel-mediated mechanism requires that the granule cell first fire an action potential; thus, the granule cell would release GABA and inhibit mitral cells prior to being inhibited itself. In contrast, NMDA receptor-mediated activation of BK channels at the granule cell soma could inhibit the granule cell prior to GABA release, producing a net disinhibitory effect on the mitral cells.

A final question is why granule cells have developed this mode of inhibition. It is well-established that odor elicits a specific map of activated glomeruli in the bulb, which has led to the suggestion that odor is “coded” by a spatial map of neuronal activity (Mori et al., 1999). Because no information is available about the connectivity of mitral cell axon collaterals, it is unclear whether NMDA receptor-mediated inhibition occurring at the granule cell soma would enhance or reduce the specificity of this spatial map. This inhibitory mechanism may be more advantageous in allowing granule cells to remain temporally tuned to the highly dynamic odorant-induced neuronal activity (Adrian, 1950). Direct coupling between NMDA receptors and BK channels would avoid the comparatively long delays in turning on and off second-messenger pathways that mediate, for example, activation of potassium currents by metabotropic glutamate receptors (Fiorillo and Williams, 1998). Indeed, NMDA receptor-mediated inhibition has been proposed to underlie the dynamic, alternating motor program in the lamprey spinal cord (Grillner et al., 2001). Whether NMDA receptor coupling to potassium channels can generate patterned activity in other systems such as the hippocampus will be interesting to see.

N.E. Schoppa and G.L. Westbrook
Vollum Institute
Oregon Health Sciences University
Portland, Oregon 97201

Selected Reading

- Adrian, E.D. (1950). *Electroencephalogr. Clin. Neurophysiol.* 2, 377–388.
- Chen, W.R., Xiong, W., and Shepherd, G.M. (2000). *Neuron* 25, 625–633.
- Fiorillo, C.D., and Williams, J.T. (1998). *Nature* 394, 78–82.
- Grillner, S., Wallen, P., Hill, R., Cangiano, L., and El Manira, A. (2001). *J. Physiol.* 533, 23–30.
- Halabisky, B., Friedman, D., Radojicic, M., and Strowbridge, B.W. (2000). *J. Neurosci.* 20, 5124–5134.
- Isaacson, J.S., and Murphy, G.J. (2001). *Neuron* 31, this issue, 1027–1034.
- Knaus, H.G., Schwarzer, C., Koch, R.O., Eberhart, A., Kaczorowski, G.J., Glossmann, H., Wunder, F., Pongs, O., Garcia, M.L., and Sperk, G. (1996). *J. Neurosci.* 16, 955–963.
- Marrion, N.V., and Tavalin, S.J. (1998). *Nature* 395, 900–905.
- Mori, K., Nagao, H., and Yoshihara, Y. (1999). *Science* 286, 711–715.
- Nicoll, R.A., and Alger, B.E. (1981). *Science* 212, 957–959.
- Wellis, D.P., and Scott, J.W. (1990). *J. Neurophysiol.* 64, 932–947.
- Zorumski, C.F., Thio, L.L., Clark, G.D., and Clifford, D.B. (1989). *Neurosci Lett.* 99, 293–299.